

Micro Wire Products, Inc.

THRIFT STORE FIXTURES • COLLECTION BINS • MATERIAL HANDLING EQUIPMENT



Micro Wire Products, Inc www.microwire-products.com

Tel: 508-584-0200 Fax:508-584-1188

TABLE OF CONTENTS

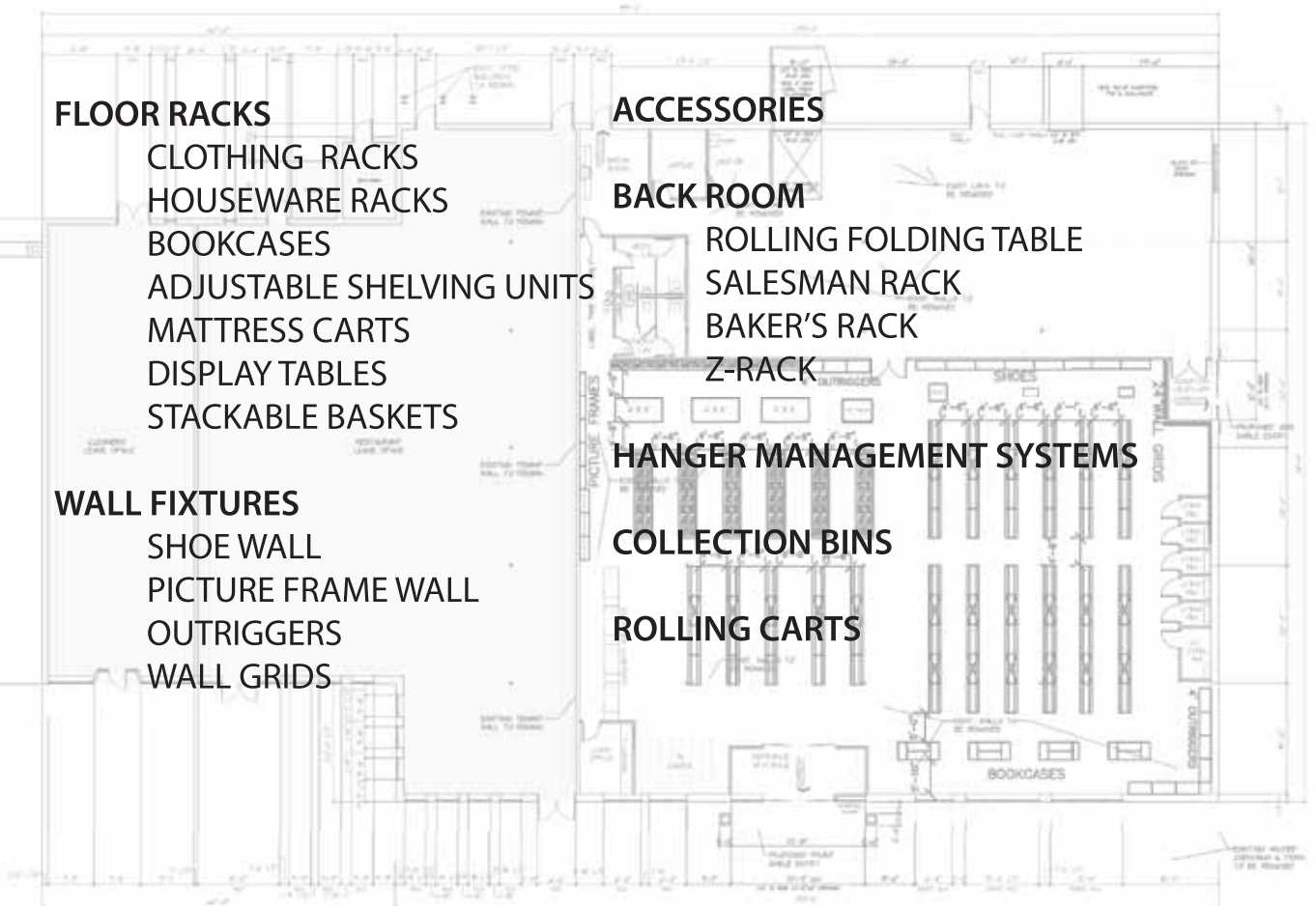

Micro Wire Products, Inc. is a diverse domestic and international manufacturer serving numerous markets. We are pleased to present our Thrift Store - Collection Bin - Material Handling Equipment Catalogue for your consideration. This catalogue presents the most popular items we provide to this marketplace.

We are custom manufacturers with a national customer base, so if you do not find what you want, let's talk about your requirements. We can manufacture most anything to meet your requirement at competitive pricing.

We would be pleased to work with your team in developing store layouts and design ideas. We have provided CAD drawings for customer use. Based on your layout, we would offer fixture pricing estimates and shipping costs. Some of our customers take advantage of our fixture installation services as well.

We strive to offer great value and service in our business friendships. Long term relations are highly valued and we will strive to deliver top quality and on time deliveries. We can also connect you with our leasing partners, should you desire to investigate those opportunities.

Thank you so much for your time and consideration.

Very truly,
Jeffrey L. Weafer, Sr.- President
Micro Wire Products, Inc.
Brockton, MA



FLOOR RACKS



MICRO-211-4
Add-on Hangrail for
Double Bar Rack Chrome
w/tear drop ends



MICRO-211-2
Grid Rack Topper for Rectangular Rack Chrome



MIRROR



Z-BRACE OPTIONAL

MICRO-211-1 ADJUSTABLE DOUBLE BAR RACK CHROME



MICRO-530-1 SQUARE GRID DUMP BIN

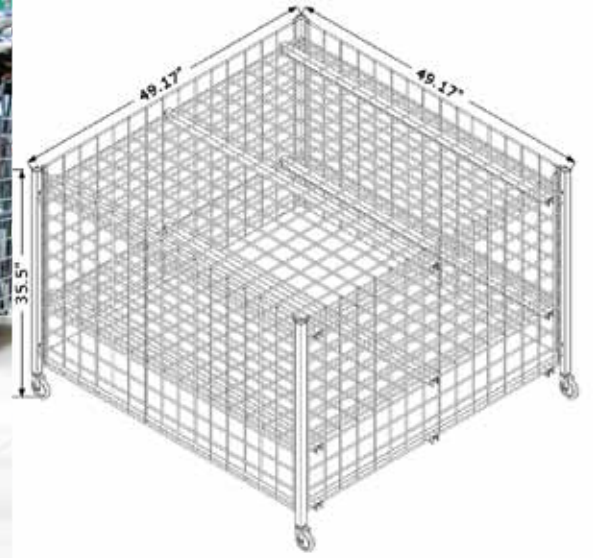

BOOK CASE 48X24X60

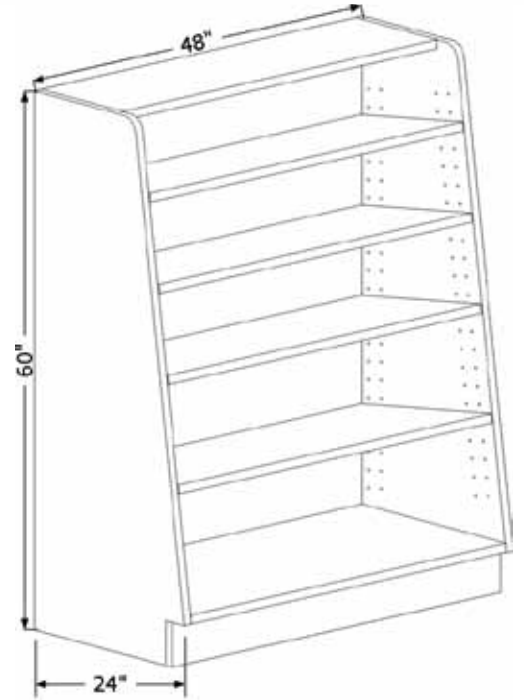

ADJUSTABLE OPEN WIRE SHELVING UNIT
END UNIT 18X36
INLINE UNIT 18X48



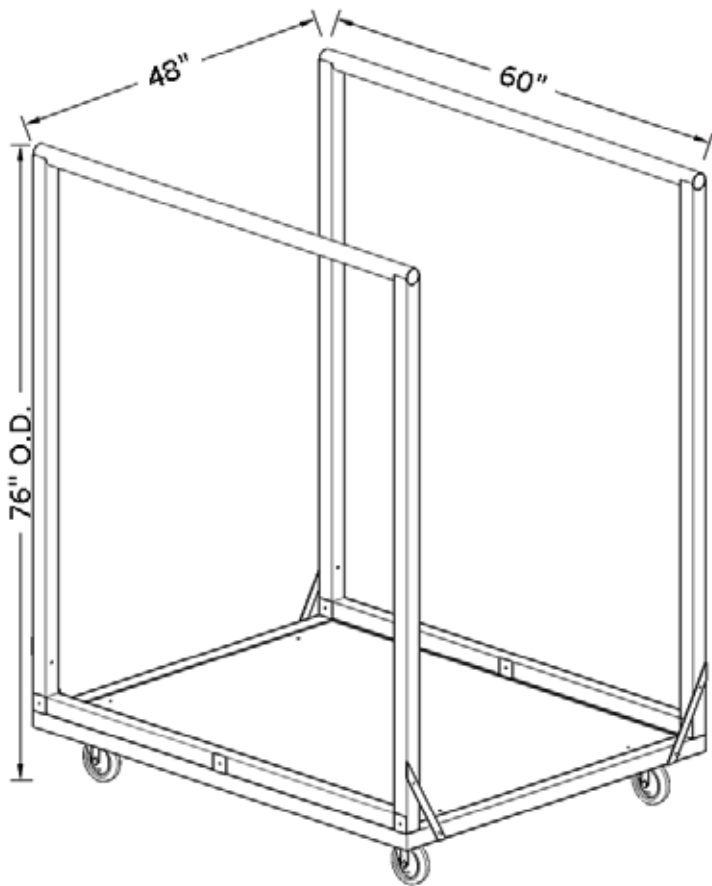

MATTRESS CART 48X60X72



STACKABLE BASKETS

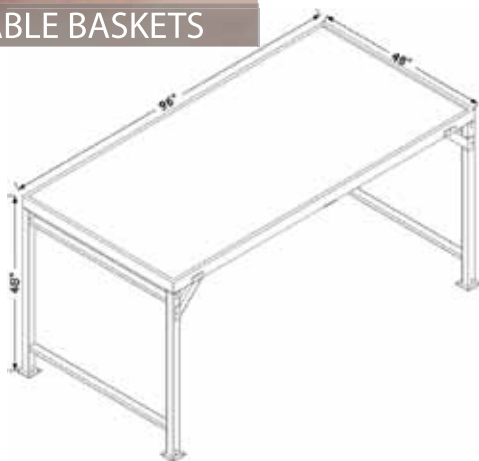

48X 96 DISPLAY TABLE

WALL FIXTURES



SHOE WALL (5' SECTIONS)
NOTE: CAN BE ALSO BE
PURCHASED FLOOR STAND
DOUBLE-SIDED

2 POSITION SHELVES
Straight Flat Shelf or
Downslant

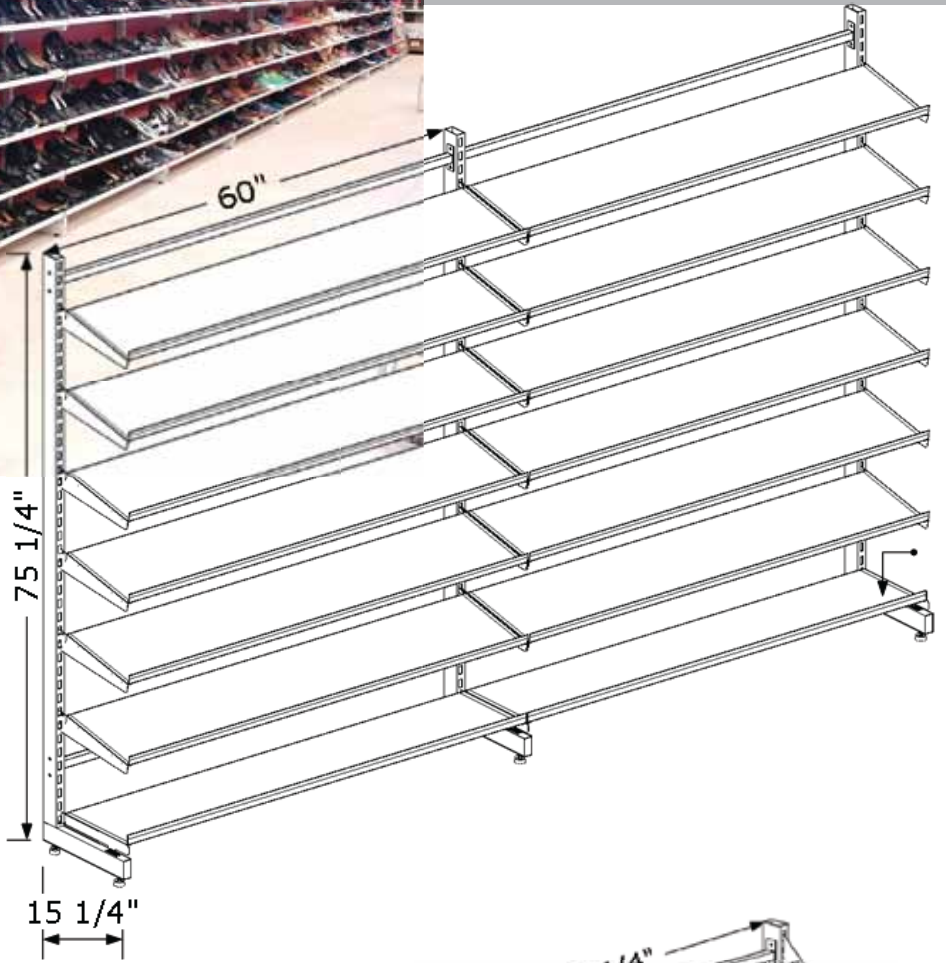

PICTURE FRAME WALL

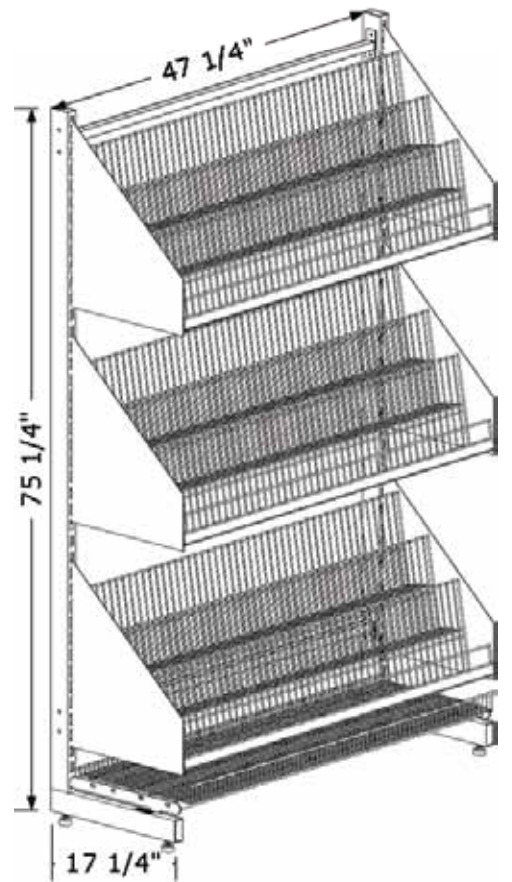



MICRO-GR12
12" Bracket for 1/2" x
1-1/2" Rectangular
Tubing

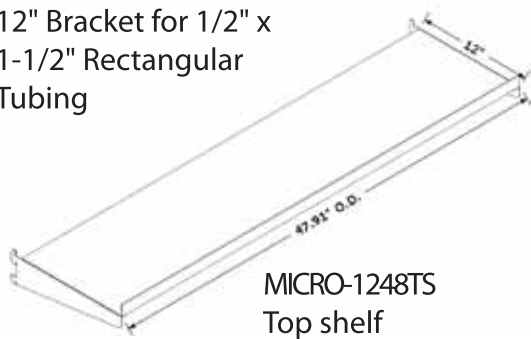

MICRO-1248TS
Top shelf



MICRO-400-3
Heavy Weight Single Slot
Wall Standard



OUTRIGGER W/ TOP SHELF (4' SECTIONS)

MICRO-2472
24"x72" Wall Grid



MICRO-321-1
5 Hook Rectangular tubing
waterfall for grid

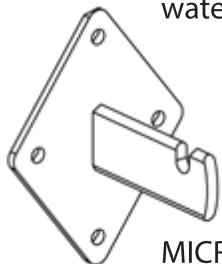

MICRO-332-1
Wall Mounting Bracket
for grid



WALL GRID (24" SECTIONS)

ACCESSORIES



MICRO-226
Hanger Stackers

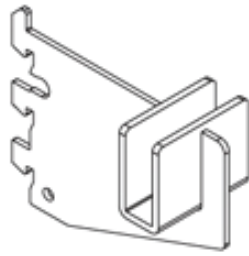

MICRO-433
Rectangular Tube Stub
Bracket
Available in 12" lengths
MICRO-433A

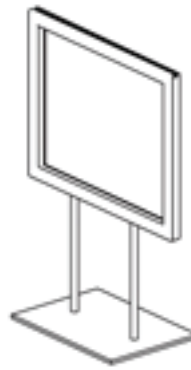

MICRO-227-2
Chrome Frame Twin
Stem Signholder

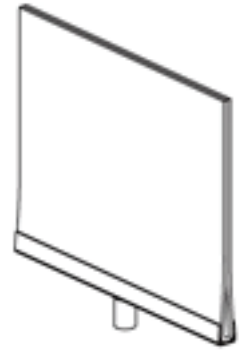

MICRO-227-4
Acrylic Horizontal
Signholder 7"x11"
* Other sizes available
upon request



MICRO-393-7
End Cap for Rect.
tubing Chrome



MICRO-393-8
Splicer for
1/2"x1"-1/2" Rect.
tubing



MICRO-RE4
1/2"x1"-1/2" Rect. tubing



BACK ROOM

ROLLING FOLDING TABLE WITH DROP LEAFS

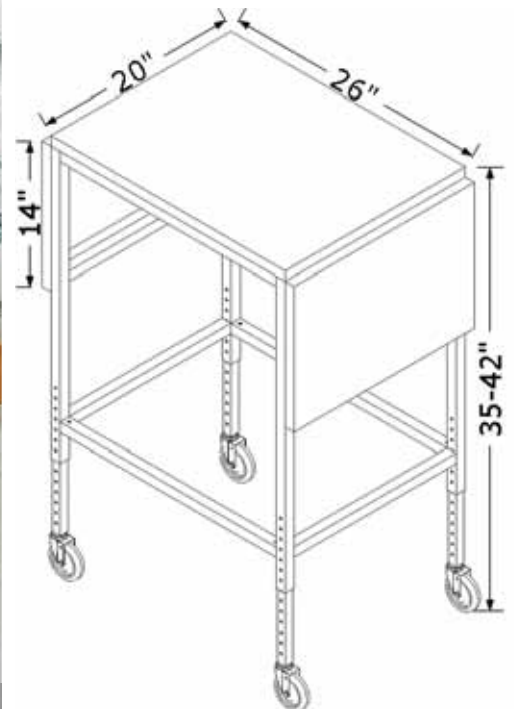



MICRO-215 FOLDING SALESMAN RACK



BAKER'S RACK



Z-RACK

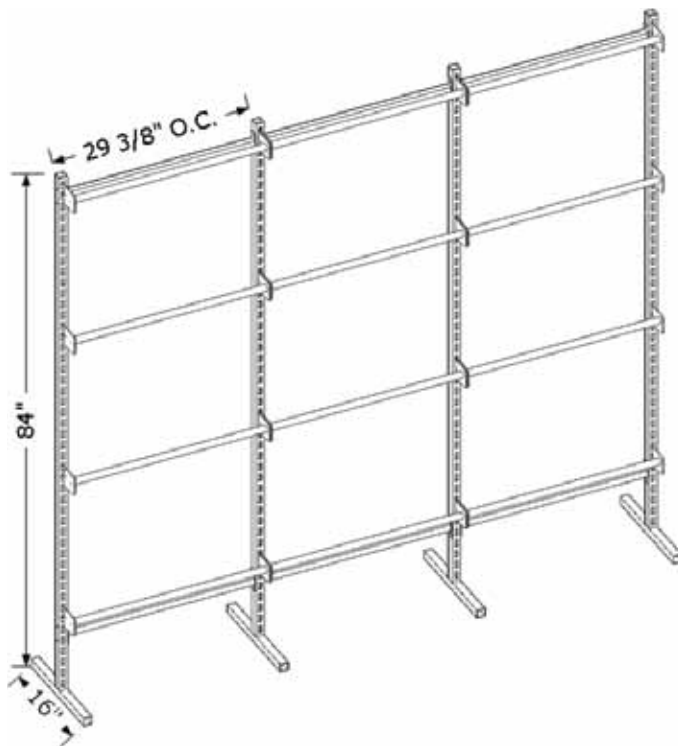

HANGER MANAGEMENT SYSTEMS

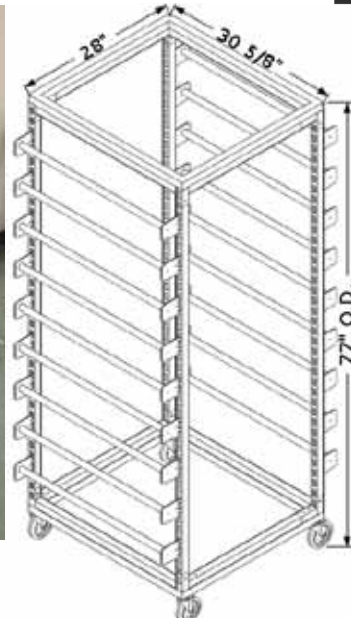
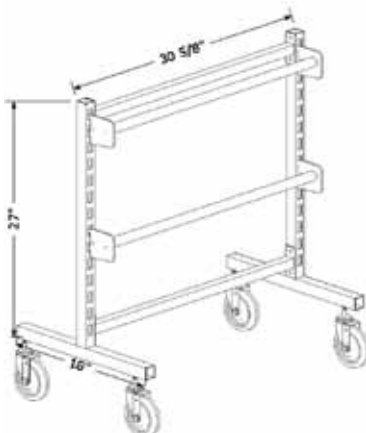

DROBOXES



56.5Wx55Dx71.5H



56Wx65Dx82H



56Wx63Dx81H



46WX44DX76H



49Wx32Dx78H Indoor Box

Micro Wire Products is a Domestic and International Manufacturer of :

- custom dropboxes
- rolling carts
- material handling equipment

If you have any current challenges or opportunities, you will find we are the most responsive and economical.



44Wx44Dx82H

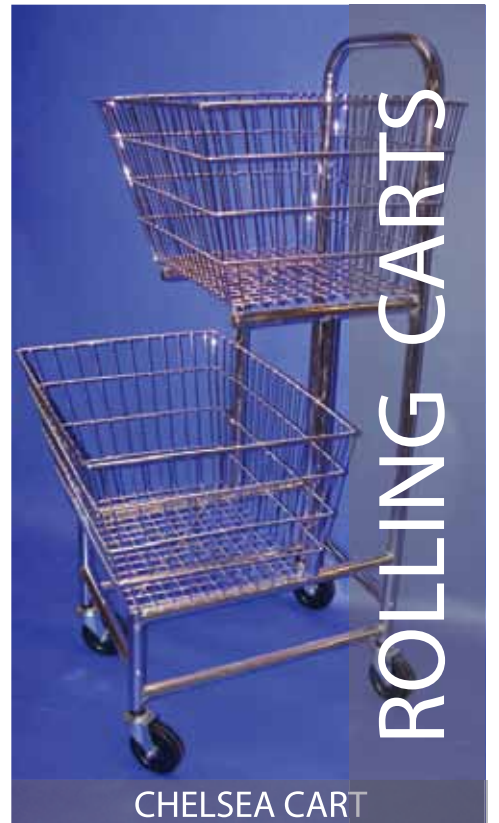

ROLLING CARTS

CHELSEA CART



28X48X72



GAYLORD STYLE STACKABLE
SPINNABLE GAYLORD CARTS W/ GRID



END DROP 42x48x76



SIDE DROP 42x48x76



Micro Wire Products, Inc.

120 N. Main St

PO Box 4440

Brockton, Ma 02303-4440

Tel: 508-584-0200

Fax: 508-584-1188

www.microwire-products.com